

NO.	REV. BY	DESCRIPTION	DATE

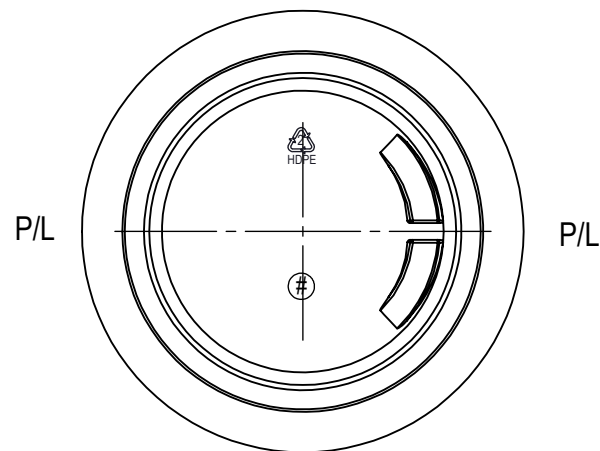

BOTTLE SPECIFICATIONS			
MATERIAL: HDPE	FILL CAPACITY: 1183 ML ± 20ML		
WEIGHT: 60g ± 2.5g	O/F CAPACITY: 1230 ML ± 20ML		
NECK SPECIFICATIONS			
FINISH	M28 SP410	"L" DIM.	.470
STYLE	M	"W" DIM.	N/A
"T" DIM.	Ø 1.078 ± .010	HELIX ANG.	2°57'
"E" DIM.	Ø .984 ± .010	T.P.I	6
"I" DIM.	N/A	PITCH	.167
BEAD DIA.	N/A	CUTTER DIA.	.500
"H" DIM.	.708 ± .015	THREAD TURNS	1.5
"S" DIM.	.046 ± .015		

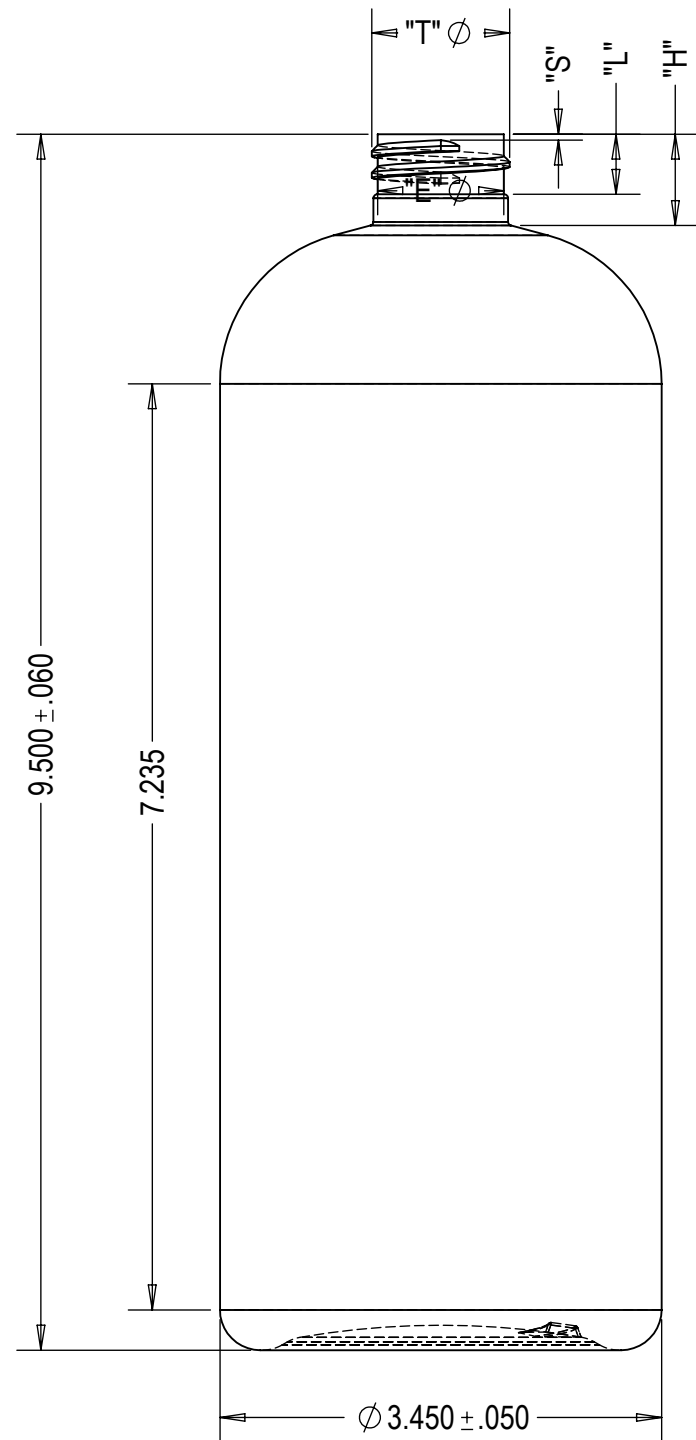

DWN. BY: A.P	DATE: 10/18/17	DESCRIPTION: 40 OZ BOSTON ROUND
APR. BY:	DATE:	DRAWING NO.: C93-4226-1-1A
SCALE: 2:3		